

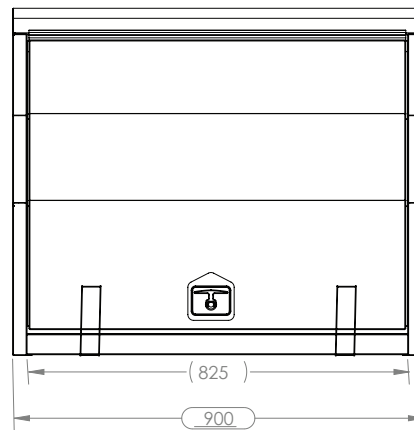

Toolboxes

900 ST Toolbox

Toolbox Series

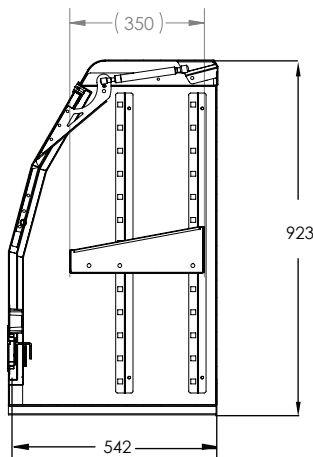
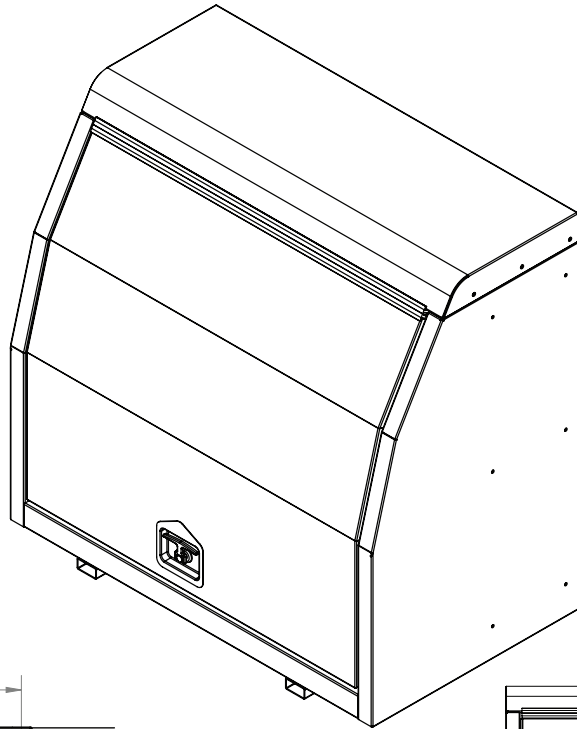

Model Description

The 900 ST Toolbox is a heavy duty toolbox designed for the tough applications. Manufactured from 2.5mm aluminium. Standard with one (1) full width Swing up door is supported with gas struts and stainless steel door locks

Designed and Australian Made – Quality

- Chromate dipped and Powdered coated in a wide range of colours
- All toolboxes are water and dust resistant – protecting your valuable equipment

Dimensions

Width: 900mm - Height: 923mm - Depth: 542mm

Ideal for use in the following industries

- Field Service
- Building
- Transport

Warranty

- 3 years standard

Key Advantage

- Robust construction

Contact Details:

Head Office

28-30 Quality Drive
Dandenong South
Victoria 3175

Freecall: 1300 131 574

P: 03 8791 7575

F: 03 9794 5681

W: www.ridgebackbodies.com.au

E: info@ridgebackbodies.com.au

